

Product manual

Vandal resistant switch MCS 19

**CONTENTS**

**CONTENTS** ..... 1

**1 PRODUCT DESCRIPTION** ..... 2

1.1 Zinc diecasting version ..... 2

1.2 Zinc diecasting / Stainless steel version ..... 2

1.3 Stainless steel version ..... 2

1.4 Varnished version ..... 2

**2 TECHNICAL DATA AND DIMENSIONAL DRAWINGS** ..... 3

2.1 Technical data ..... 3

2.2 Component dimensions ..... 5

2.2.1 Component dimensions non-illuminated ..... 5

2.2.2 Component dimensions illuminated ..... 6

2.3 Drilling diagram ..... 7

2.4 Circuit diagram ..... 7

2.5 Assembly ..... 7

**3 ORDER NUMBERS** ..... 8

3.1 Zinc diecasting version ..... 8

3.2 Stainless steel version ..... 8

3.3 Varnished version without lettering and illumination ..... 9

3.4 Varnished version with lettering ..... 9

3.5 Varnished version with lettering and illumination ..... 10

3.6 Lettering ..... 11

**4 PACKAGING** ..... 12

**5 QUALIFICATION TESTS** ..... 13

5.1 IP Protection class ..... 13

5.2 IK Protection class ..... 13

5.3 Salt spray test ..... 13

**6 APPROVALS** ..... 14

Changes that contribute to technical improvement are subject to alternations

Seite	Erstelldatum:	Ersteller:	Änderungsdatum:	Geändert von:	Änderungs-Nr.	Datenblatt Nr.	Index
1 of 14	13.06.06	SHO	07.12.2010	Birmelin	10319	105.9515	b

## 1 DESCRIPTION

- vandal resistant switch for front panel mounting as well as for complete housings
- front design is metal made and the mounting style of the front is with 1 mm nearly even, the switches are lined up with a spacing of 25 mm
- fixing with a nut M19x0.75 width across flats 22
- option: anti-rotation mounting with a D-area integrated to the mounting hole, tight mounting by using indicated sealing ring
- terminals: two contact pins with a spacing of 7.62 mm
- available with pins, pins with soldering aid and clip for pins

### 1.1 Zinc diecasting version

- - actuator and housing consist of cast zinc
- - not lettered and not illuminated
- - ideal for indoor applications

### 1.2 Zinc-diecasting / Stainless steel version

- actuator is made of stainless steel and the housing consists of cast zinc
- optionally: point illumination integrated into the actuator and laser lettering with standard or customer-specific symbols

### 1.3 Stainless steel version

- actuator and housing consist of high-quality stainless steel
- optionally: point illumination integrated into the actuator and laser lettering with standard or customer-specific symbols
- by using this robust weatherproof material, this version is ideal for rough environment and outdoor applications

### 1.4 Varnished version

- two versions: either both housing and actuator are made of cast zinc or the housing is made of cast zinc and the actuator of stainless steel
- colour adjustments for customer housings are possible; alternatively, the actuator or the switch housing can be varnished according to the provided colour specifications; as standard the signal colours red, green and yellow are available
- after the laser lettering, the varnished actuators are sealed by transparent lacquer
- for the zinc-diecasting / stainless steel version, optionally point illumination integrated into the actuator and laser lettering with standard or customer-specific symbols

Changes that contribute to technical improvement are subject to alternations

Seite	Erstelldatum:	Ersteller:	Änderungsdatum:	Geändert von:	Änderungs-Nr.	Datenblatt Nr.	Index
2 of 14	13.06.06	SHO	07.12.2010	Birmelin	10319	105.9515	b

## 2 TECHNICAL DATA AND DIMENSIONAL DRAWINGS

### 2.1 Technical data

<b>Electrical Data</b>		Contact Material Gold	Contact Material Silver
Switching Voltage max.	(VDC)	24	48
Switching Voltage min.	(VDC)	50 mV	4
Switching Current max.	(mA)	80	125
Rated Breaking Capacity	(W)	0.36	1.2
Lifetime (at Rated Breaking capacity)	(mill.)	1	1
Initial Contact Resistance. new	(mΩ)	≤ 50	≤ 50
Initial Contact Resistance (after. 1 mill.)	(mΩ)	≤ 150	≤ 150
Insulation Resistance	(kΩ)	> 100.000	> 100.000
Duration of Bounce typ.	(ms)	< 5	< 5

<b>Mechanical Data</b>		
Actuating Force (min.)	(N)	3.7
Actuating Travel	(mm)	0.4
Lifetime (mechanical)	(mill.)	1
Starting Torque		
with Sealing Ring	(Nm)	0.4
without Sealing Ring	(Nm)	1.5

<b>Climatical Data</b>		
Operating Temperature	(°C)	-20 to +60
Storage Temperature	(°C)	-20 to +60

Changes that contribute to technical improvement are subject to alternations

Seite	Erstelldatum:	Ersteller:	Änderungsdatum:	Geändert von:	Änderungs-Nr.	Datenblatt Nr.	Index
3 of 14	13.06.06	SHO	07.12.2010	Birmelin	10319	105.9515	b

<u>Point Illumination</u>	<b>Attention: Switches without built-in resistance</b>		
	Forward Current max. (mA)	Forward Voltage at IF=10mA	Forward Voltage at IF=20mA
Characteristics <b>red LED</b>	40	2 VDC	
Characteristics <b>green LED</b>	40	2 VDC	
Characteristics <b>yellow LED</b>	40	2 VDC	
Characteristics <b>blue LED</b>	20	3.2 VDC	
Characteristics <b>red/green LED</b>	25		2.0 / 2.2 VDC

<u>Soldering Suggestion</u>	
Tinning according to DIN IEC 60068-2-20	260°C / 2s
Solderability according to IEC 68-2-20 Test Ta Method 1	260°C / 2s
Resistance to Soldering Heat according to IEC 68-2-20 Test Tb Method 1A	260°C / 5s

<u>Materials</u>	
<b>Component</b>	<b>Material</b>
Socket	PA
Housing	Stainless steel 1.4305
	Zinc diecasting nickel plated
Actuator unlettered	Zinc diecasting nickel plated
Actuator lettered	Stainless steel 1.4305
Snap Dome	X 12 CrNi 177 gold plated
Contacts	CuZn37 2,5µm Ag

Changes that contribute to technical improvement are subject to alternations							
Seite	Erstelldatum:	Ersteller:	Änderungsdatum:	Geändert von:	Änderungs-Nr.	Datenblatt Nr.	Index
4 of 14	13.06.06	SHO	07.12.2010	Birmelin	10319	105.9515	b

## 2.2 Component dimensions

### 2.2.1 Component dimensions non-illuminated

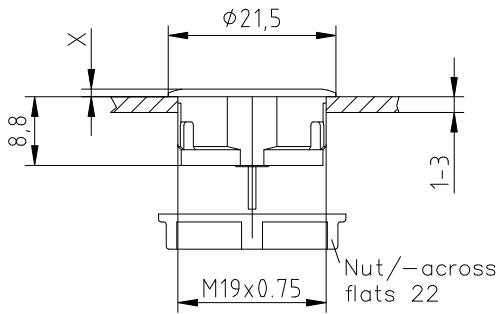

	zinc die casting	stainless steel
without sealing ring	X = 1mm	X = 1mm
with sealing ring	X = 2mm	X = 1,7mm

#### Models

standard

with soldering aid

with clip

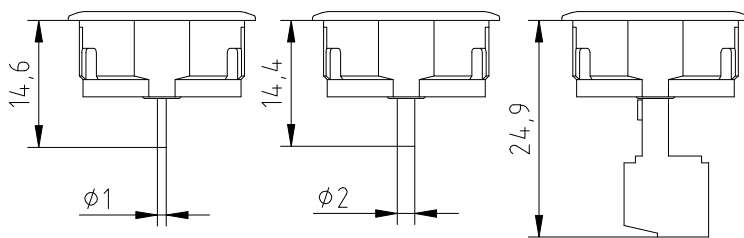

#### Lettering posititon

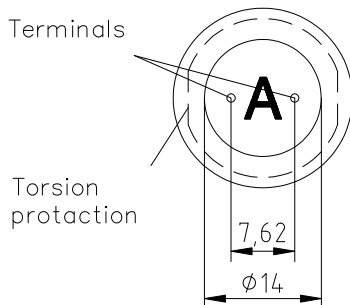

Changes that contribute to technical improvement are subject to alternations

Seite	Erstelldatum:	Ersteller:	Änderungsdatum:	Geändert von:	Änderungs-Nr.	Datenblatt Nr.	Index
5 of 14	13.06.06	SHO	07.12.2010	Birmelin	10319	105.9515	b

2.2.2 Component dimensions illuminated

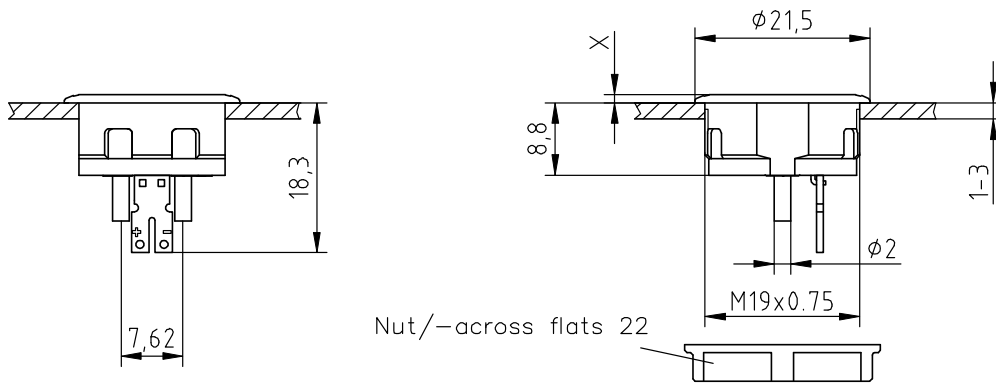

Lettering position

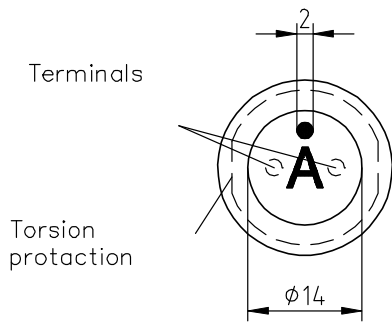

	zinc die casting	stainless steel
without sealing ring	X = 1mm	X = 1mm
with sealing ring	X = 2mm	X = 1,7mm

### 2.3 Drilling diagram

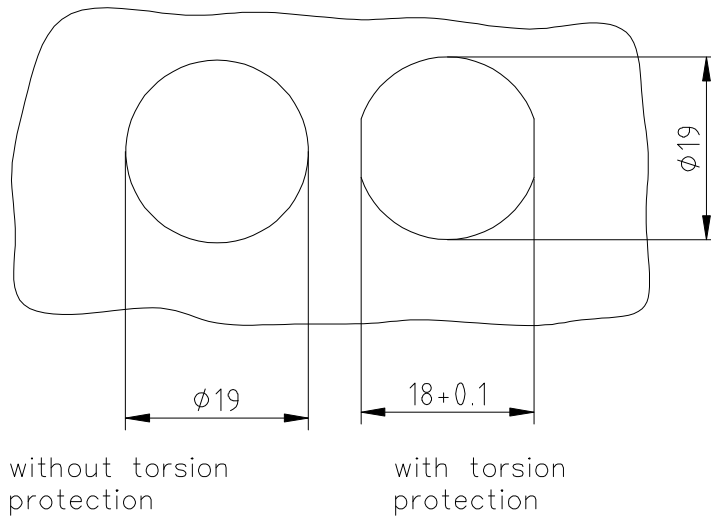

### 2.4 Circuit diagram

Circuit diagram

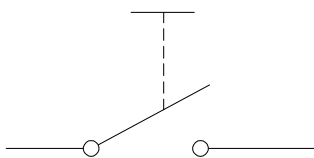

Bi-color-LED

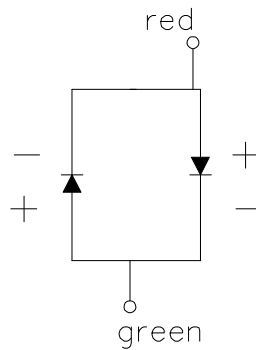

### 2.5 Zubehör

All versions are supplied with nut and sealing ring, part number 0098.9219.  
The clip for terminal pins can also be ordered separately, part number 0701.9233.

Changes that contribute to technical improvement are subject to alternations							
Seite	Erstelldatum:	Ersteller:	Änderungsdatum:	Geändert von:	Änderungs-Nr.	Datenblatt Nr.	Index
7 of 14	13.06.06	SHO	07.12.2010	Birmelin	10319	105.9515	b

### 3 ORDER NUMBERS

#### 3.1 Zinc diecasting version

Part number	Housing	Actuaor	Terminal	Contacts	Illumination
1241.2800	Zinc diecasting	Zinc diecasting	standard	silver	-----
1241.2801	Zinc diecasting	Zinc diecasting	with soldering aid	silver	-----
1241.2802	Zinc diecasting	Zinc diecasting	with clip	silver	-----
1241.2805.XXX	Zinc diecasting	Stainless steel	standard	silver	-----
1241.2806.XXX	Zinc diecasting	Stainless steel	with soldering aid	silver	-----
1241.2807.XXX	Zinc diecasting	Stainless steel	with clip	silver	-----
1241.2810	Zinc diecasting	Zinc diecasting	standard	gold	-----
1241.2812	Zinc diecasting	Zinc diecasting	with clip	gold	-----
1241.2815.XXX	Zinc diecasting	Stainless steel	standard	gold	-----
1241.2817.XXX	Zinc diecasting	Stainless steel	with clip	gold	-----
1241.2855.XXX	Zinc diecasting	Stainless steel	with soldering aid	silver	red
1241.2856.XXX	Zinc diecasting	Stainless steel	with soldering aid	silver	green
1241.2857.XXX	Zinc diecasting	Stainless steel	with soldering aid	silver	yellow
1241.2858.XXX	Zinc diecasting	Stainless steel	with soldering aid	silver	red-green
1241.2859.XXX	Zinc diecasting	Stainless steel	with soldering aid	silver	blue

----- Legend index (see page 11)

#### 3.2 Stainless steel version

Part number	Housing	Actuator	Terminal	Contacts	Illumination
1241.2820.XXX	Stainless steel	Stainless steel	standard	silver	-----
1241.2821.XXX	Stainless steel	Stainless steel	with soldering aid	silver	-----
1241.2822.XXX	Stainless steel	Stainless steel	with clip	silver	-----
1241.2825.XXX	Stainless steel	Stainless steel	standard	gold	-----
1241.2827.XXX	Stainless steel	Stainless steel	with clip	gold	-----
1241.2830.XXX	Stainless steel	Stainless steel	with soldering aid	silver	red
1241.2831.XXX	Stainless steel	Stainless steel	with soldering aid	silver	green
1241.2832.XXX	Stainless steel	Stainless steel	with soldering aid	silver	yellow
1241.2833.XXX	Stainless steel	Stainless steel	with soldering aid	silver	red-green
1241.2834.XXX*	Stainless steel	Stainless steel	with soldering aid	silver	blue

----- Legend index (see page 11)

with “ \* “ marked part number on request





### 3.6 Lettering

The last three digits in the order no. define the lettering.

000	No lettering
001-074	Standard lettering
101-	Customized lettering

#### Example for ordering an lettering

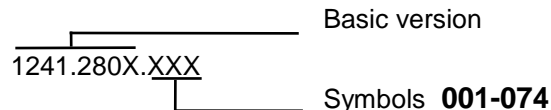

#### Ordering Indices for Lettering

001= <b>A</b>	016= <b>P</b>	031= <b>4</b>	046= ↕	061= <b>EIN</b>
002= <b>B</b>	017= <b>Q</b>	032= <b>5</b>	047= →	062= <b>AUS</b>
003= <b>C</b>	018= <b>R</b>	033= <b>6</b>	048= ←	063= <b>AUF</b>
004= <b>D</b>	019= <b>S</b>	034= <b>7</b>	049= ↓	064= <b>AB</b>
005= <b>E</b>	020= <b>T</b>	035= <b>8</b>	050= ↑	065= <b>ON</b>
006= <b>F</b>	021= <b>U</b>	036= <b>9</b>	051= %	066= <b>OFF</b>
007= <b>G</b>	022= <b>V</b>	037= +	052= √	067= <b>UP</b>
008= <b>H</b>	023= <b>W</b>	038= –	053= <b>CTRL</b>	068= <b>DOWN</b>
009= <b>I</b>	024= <b>X</b>	039= .	054= <b>RETURN</b>	069= <b>HIGH</b>
010= <b>J</b>	025= <b>Y</b>	040= ×	055= <b>SHIFT</b>	070= <b>LOW</b>
011= <b>K</b>	026= <b>Z</b>	041= ÷	056= <b>LOCK</b>	071= <b>ON/OFF</b>
012= <b>L</b>	027= <b>0</b>	042= *	057= <b>STOP</b>	072= <b>START</b>
013= <b>M</b>	028= <b>1</b>	043= =	058= <b>ENTER</b>	073= <b>RESET</b>
014= <b>N</b>	029= <b>2</b>	044= #	059= <b>BACK</b>	074=
015= <b>O</b>	030= <b>3</b>	045= ↔	060= <b>LINE</b>	

#### Font size

Single characters:	height 5 mm, font size: Helvetica normal DIN1451 E1
Legends, max. 6 characters:	height 2,5 mm, font size: Helvetica condensed DIN1451-3E
Symbols (Indice 037-052):	capitals height 5 mm, font size: True Type, Symbol

#### Standard colour for lettering

Stainless steel: black ( filled lettering )

Changes that contribute to technical improvement are subject to alternations							
Seite	Erstelldatum:	Ersteller:	Änderungsdatum:	Geändert von:	Änderungs-Nr.	Datenblatt Nr.	Index
11 of 14	13.06.06	SHO	07.12.2010	Birmelin	10319	105.9515	b

#### 4 PACKAGING

##### MSC 19 Switch

MSC 19	standard and with soldering aid	20 pieces per box with inlay
MCS 19	with clip	10 pieces per box with inlay

The nuts and sealing ring are packed separately and are enclosed in the box.



Changes that contribute to technical improvement are subject to alternations							
Seite	Erstelldatum:	Ersteller:	Änderungsdatum:	Geändert von:	Änderungs-Nr.	Datenblatt Nr.	Index
12 of 14	13.06.06	SHO	07.12.2010	Birmelin	10319	105.9515	b

## 5 QUALIFICATION TESTS

### 5.1 IP Protection class

IP degree of protection IEC/DIN/EN/ 60529	from the front	IP 40
	Switching unit	IP 65

### 5.2 IK Protection class

Test carried out centrally.

IK protection class DIN EN 50102	IK 05
-------------------------------------	-------

### 5.3 Salt spray test

#### Stainless steel version

Salt spray test according to DIN 50021- SS  
24h, 48h and 96h residence time

The surface of the stainless steel material is covered with a molecular-passiv layer. Only under very unfavourable conditions, it is possible that iron and rust molecules as well as base metals penetrate the passive layer as foreign substances (pollutions) and initiate the rust process.

The actuation of the switch was not affected. After the residence time the tested samples were cleaned under running water and all rust spots could be removed.

#### Zinc diecasting nickel-plated

Salt spray test according to DIN 50021- SS  
24h residence time

The surface of the zinc diecasting version shows no signs off corrosion.

Changes that contribute to technical improvement are subject to alternations							
Seite	Erstelldatum:	Ersteller:	Änderungsdatum:	Geändert von:	Änderungs-Nr.	Datenblatt Nr.	Index
13 of 14	13.06.06	SHO	07.12.2010	Birmelin	10319	105.9515	b

## 6 APPROVALS

All articles are ROHS-compliant and in compliance to the EMC directive (2004/108/EWG).



Changes that contribute to technical improvement are subject to alternations							
Seite	Erstelldatum:	Ersteller:	Änderungsdatum:	Geändert von:	Änderungs-Nr.	Datenblatt Nr.	Index
14 of 14	13.06.06	SHO	07.12.2010	Birmelin	10319	105.9515	b